













Quick Installation Guide

X1/X3-EVC Series 7.2 kW-22 kW (Home Edition)

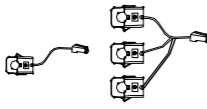
I Packing List

 EV-Charger *1	 Expansion bolt *3/5 (3 for Socket Type, 5 for Plug Type)	 Self tapping screw *3/5 (3 for Socket Type, 5 for Plug Type)	 Gasket *3/5 (3 for Socket Type, 5 for Plug Type)
 Manual *1	 Quick Installation Guide *1	 European terminal *3/5 (3 for single-phase; 5 for three-phase)	 RJ45 terminal adapter *1
 RFID Card *2	 CT (single-phase) *1 CT (three-phase) *1	 Cable hook *1 (only for Plug Type)	

II Installation Steps

Installation Steps

STEP 1: Remove the screw from the EV-Charger with the cross screwdriver. Then remove the back bracket away carefully.

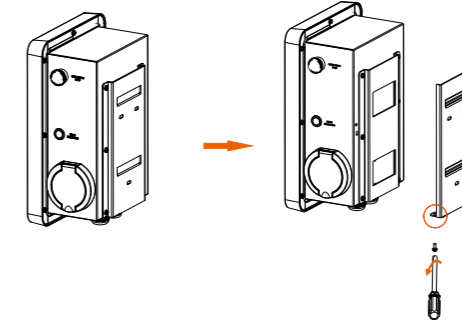

STEP 2: Fix the back bracket and the cable hook (only for Plug Type) to the wall.

- Mark the position of the holes.
- Drill holes with ϕ 8 drill.
- Depth: at least 45 mm.

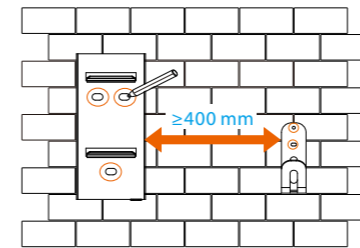

- Insert the expansion bolts.

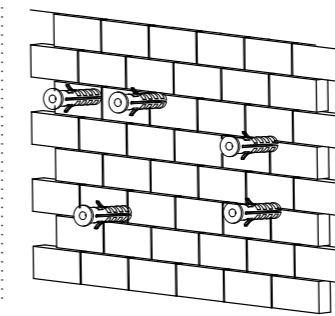

- Align the bracket and the cable hook (only for Plug Type) with the holes, and screw the self tapping screws with the cross screwdriver.

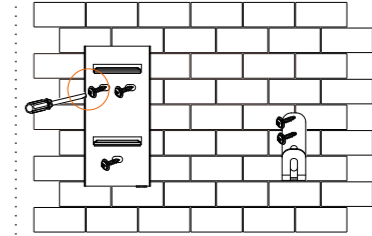

(torque:1.5~2 N·m)

STEP 3: Hang the EV-Charger on the wall for trial, then estimate the required length of input cable (three-core for single-phase, five-core for three-phase, outer diameter: 12.5-18 mm) and communication cable. After that, take the EV-Charger down.

STEP 4: Unscrew the EV-Charger's rear cover with the cross screwdriver and take it down. Then undo the fastening heads and take the waterproof materials away as shown below.

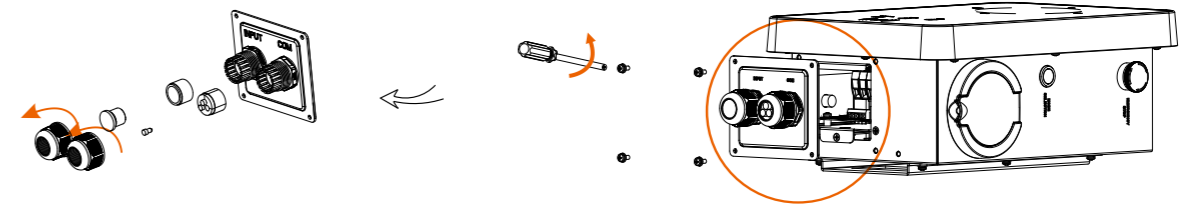

STEP 5: Unscrew the countersunk screw of the base plate of communication board with the cross screwdriver. Then pull the base plate of communication board out.

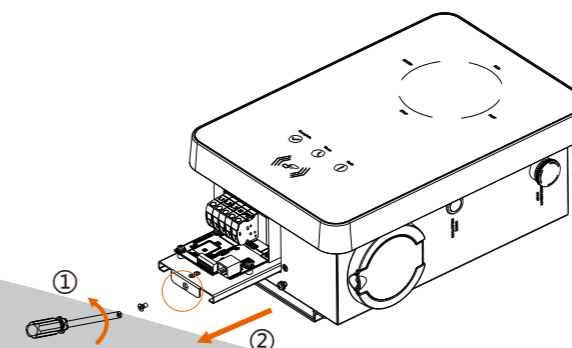

Installation Steps

STEP 6: Insert the prepared communication cable through the waterproof connector in sequence as shown below (If the cable is self-made, also insert the wires into the RJ45 terminals and then use crimping pliers to press them tightly).

STEP 7: Strip the outer sheath of the input cable for a length of 60-70 mm, ensuring all the wires can reach the terminal blocks with a little excessive length. Use the stripping pliers to strip approx. 12 mm of insulation from the end of all the coloured wires as below. Then crimp the European terminal with the wire crimper.

STEP 8: Insert the input cable through the waterproof connector in sequence as shown below.

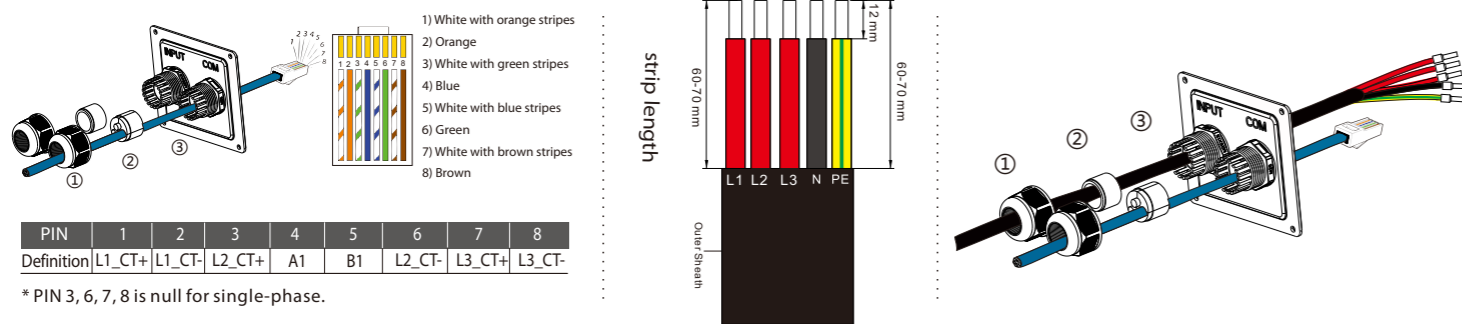

STEP 9: Insert the wires into the appropriate holes of the terminal blocks, then block the terminals with the straight screwdriver.

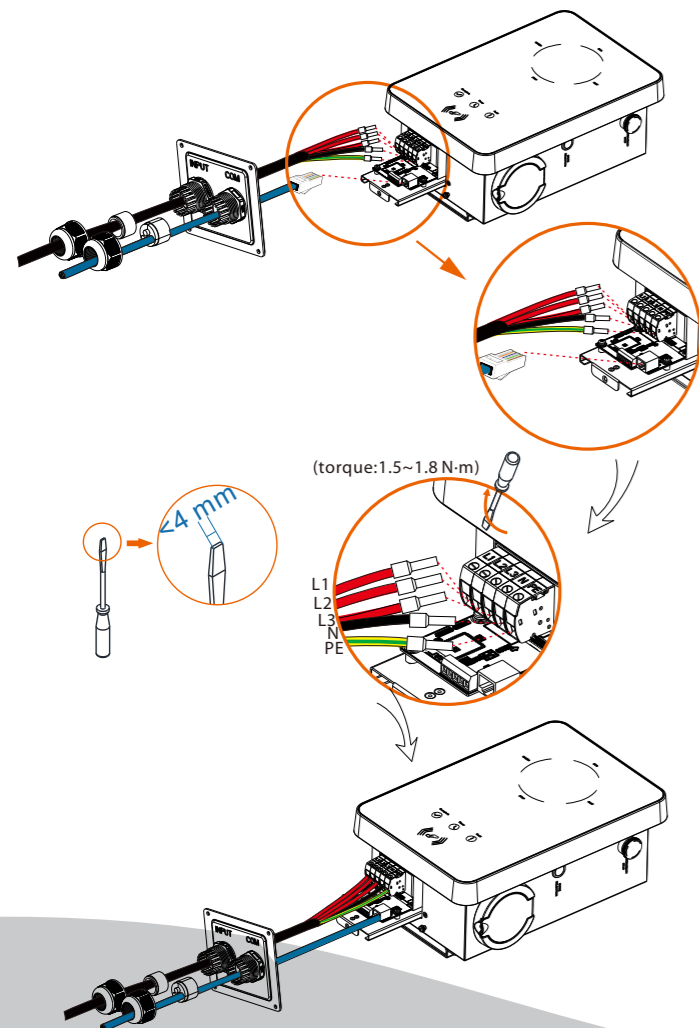

STEP 10: Press the spring upward and push the base plate of communication board in. Then screw the countersunk screw.

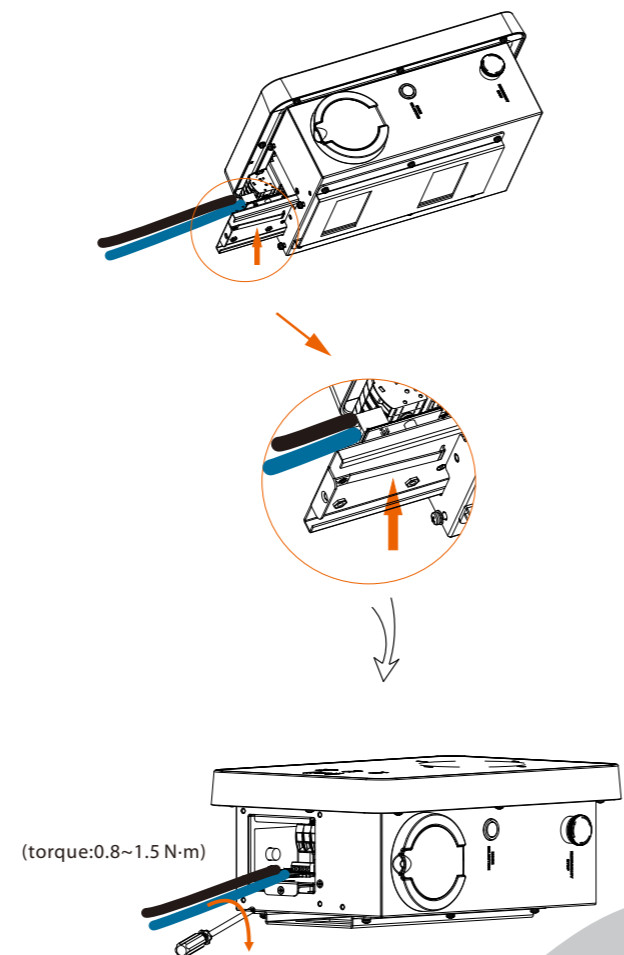

STEP 11: Push the rear cover to appropriate position of the cables and screw the self tapping screws with the cross screwdriver. Then tighten the waterproof fastening head.

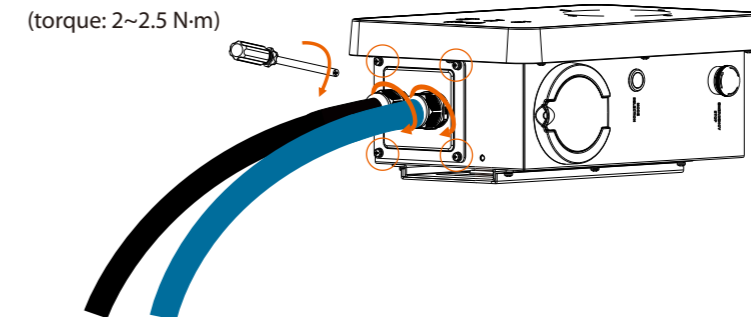

STEP 12: Hang the EV-Charger up carefully and steady the EV-Charger with the self tapping screw and the cross screwdriver.

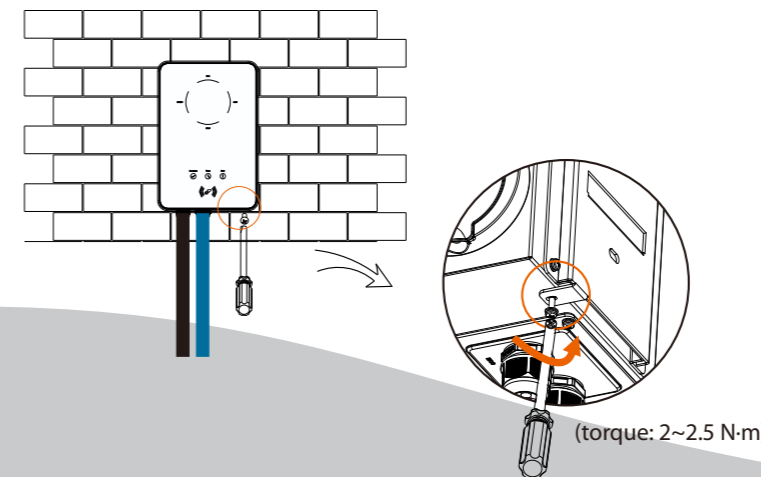

For Plug Type, connect the charging connector with the EV-Charger and hang the connecting cable on the hook.

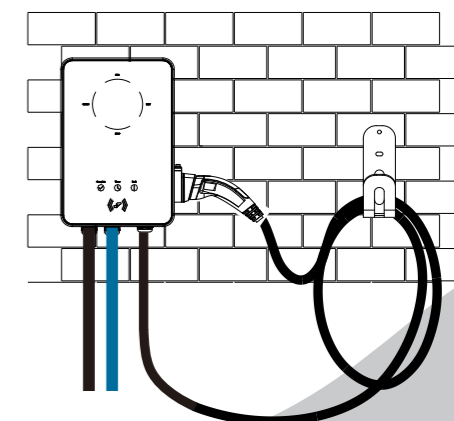

CT & WiFi Connection

► CT Connection
Diagram:

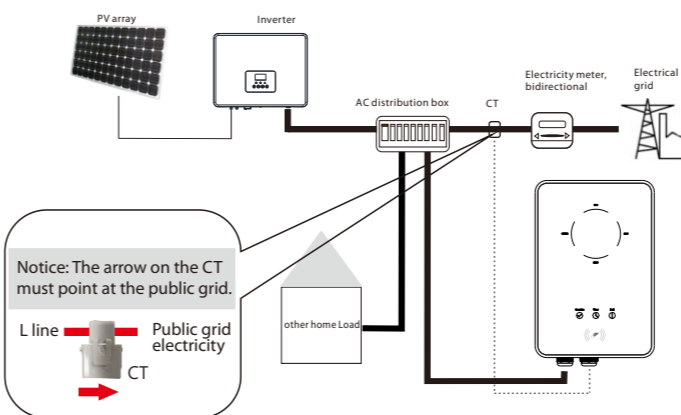

-Steady the CT on the public grid.
-Insert the other end of the communication cable and the terminal of CT on each side of the RJ45 terminal adapter.

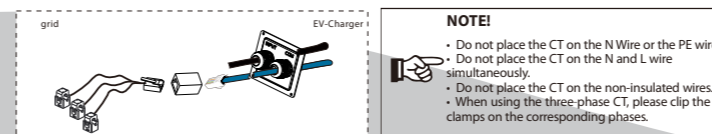

► WiFi Connection

Step 1: Use your smart phone to scan below QR code or search for the keyword "SolaXCloud" in browser to download the Monitoring App.



Step 2: Create a new account on the Monitoring App.

Step 3: Login and turn to Account page in the app. Then click "Wi-Fi Connection" and follow the instructions to complete the process.

